

**THE UNITED REPUBLIC OF TANZANIA
NATIONAL EXAMINATIONS COUNCIL
ADVANCED CERTIFICATE OF SECONDARY EDUCATION
EXAMINATION**

131/1

PHYSICS 1

(For Both School and Private Candidates)

Time 3 Hours

Tuesday, 06th May 2014 a.m.

Instructions

1. This paper consists of sections A, B and C.
2. Answer **ten (10)** questions choosing **four (4)** questions from section A and **three (3)** questions from each of sections B and C.
3. Marks for each question or part thereof are indicated.
4. Mathematical tables and non-programmable calculators may be used.
5. Cellular phones are **not** allowed in the examination room.
6. Write your **Examination Number** on every page of your answer booklet(s).
7. The following information may be useful:
 - (a) Acceleration due to gravity, $g = 9.8 \text{ m/sec}^2$
 - (b) Density of water $\rho_w = 1000 \text{ kgm}^{-3}$
 - (c) Speed of electromagnetic waves in air $= 3 \times 10^8 \text{ ms}^{-1}$
 - (d) Resistivity of Nichrome at $373\text{K} = 1.08 \times 10^{-6} \Omega\text{m}$
 - (e) Temperature coefficient resistance of Nichrome $= 8.0 \times 10^{-5} \text{ K}^{-1}$
 - (f) Gravitational constant $= 6.67 \times 10^{-11} \text{ Nm}^2\text{kg}^{-2}$
 - (g) Radius of the earth, $R_e = 6.37 \times 10^6 \text{ m}$
 - (h) Mass of the earth $= 6 \times 10^{24} \text{ kg}$
 - (i) Mass of the sun $= 2.0 \times 10^{30} \text{ kg}$
 - (j) Pi, $\pi = 3.14$.

maktaba.tetea.org



SECTION A (40 Marks)

Answer **four (4)** questions from this section.

1. (a) (i) Distinguish random error from systematic error. **(01 mark)**
(ii) Give a practical example of each term in 1 (a) (i) and briefly explain how they can be reduced or eliminated. **(02 marks)**

 - (b) (i) Define the terms error and mistake. **(01 mark)**
(ii) An experiment was done to find the acceleration due to gravity by using the formula:
$$T = 2\pi \sqrt{\frac{l}{g}}$$
, where all symbols carry their usual meaning. If the clock loses 3 seconds in 5 minutes, determine the error in measuring 'g', given that, $T = 2.22\text{sec}$, $l = 121.6\text{cm}$, $\Delta T_1 = 0.1\text{sec}$ and $\Delta l = \pm 0.05$. **(03 marks)**

 - (c) (i) What is the importance of dimensional analysis in spite of its drawbacks? **(01 mark)**
(ii) The following measurements were taken by a student for the length of a piece of rod: 21.02, 20.99, 20.92, 21.11 and 20.69. Basing on error analysis find the true value of the length of a piece of rod and its associated error. **(02 marks)**
2. (a) Outline the motions that add up to make projectile motion. **(01 mark)**

 - (b) In the first second of its flight a rocket ejects 1/60 of its mass with a relative velocity of 2400m/s.
(i) Find its acceleration. **(02 marks)**
(ii) What is the final velocity if the ratio of initial to final mass of the rocket is 4 at a time of 60 seconds? **(2.5 marks)**

 - (c) A ball is thrown upwards with an initial velocity of 33m/s from a point 65° on the side of a hill which slopes upward uniformly at an angle of 28° .
(i) At what distance up the slope does the ball strike? **(03 marks)**
(ii) Calculate the time of flight of the ball. **(1.5 marks)**
3. (a) (i) State the principle of conservation of linear momentum. **(01 mark)**
(ii) Give two examples of the principle stated in 3 (a) (i). **(01 marks)**

 - (b) A cannon of mass 1300kg fires a 72kg ball in a horizontal direction with a muzzle speed of 55m/s. If the cannon is mounted so that it can recoil freely calculate the:
(i) recoil velocity of the cannon relative to the earth. **(03 marks)**
(ii) horizontal velocity of the ball relative to the earth. **(01 mark)**

 - (c) (i) Define the term 'radial acceleration'. **(01 mark)**
(ii) An insect is released from rest at the top of the smooth bowling ball such that it slides over the ball. Prove that it will lose its footing with the ball at an angle of about 48° with the vertical. **(03 marks)**

4. (a) (i) State where the magnitude of acceleration is greatest in a simple harmonic motion (S.H.M.)? **(01 mark)**
(ii) Sketch a graph of acceleration against displacement for a simple harmonic motion. **(1.5 marks)**
- (b) A vertical spring fixed at one end has a mass of 0.2kg and is attached at the other end. Determine the:
(i) Extension of the spring. **(02 marks)**
(ii) Energy stored in the spring. **(1.5 marks)**
- (c) The displacement of a particle from the equilibrium position moving with simple harmonic motion is given by $x = 0.05\sin 6t$, where t is time in seconds measured from an instant when $x = 0$. Calculate the:
(i) Amplitude of oscillations. **(01 mark)**
(ii) Period of oscillations. **(1.5 marks)**
(ii) Maximum acceleration of the particle. **(1.5 marks)**
5. (a) (i) Define the universal gravitational constant. **(01 mark)**
(ii) How is gravitational potential related to gravitational field strength? **(1.5 marks)**
- (b) (i) Write down an expression for the acceleration due to gravity (g) of a body of mass m which is at a distance r from the centre of the earth. **(01 mark)**
(ii) If the earth were made of lead of relative density of 11.3, what would be the value of acceleration due to gravity on the surface of the earth? **(2.5 marks)**
- (c) (i) Why the value of acceleration due to gravity (g) changes due to the change in latitude? Give two reasons. **(02 marks)**
(ii) A rocket is fired from the earth towards the sun. At what point on its path is the gravitational force on the rocket zero? **(02 marks)**
6. (a) (i) Define torque and give its S.I. unit. **(01 mark)**
(ii) A disc of moment of inertia $2.5 \times 10^{-4} \text{kgm}^2$ is rotating freely about an axis through its centre at 20rev/min . If some wax of mass 0.04kg is dropped gently on to the disc 0.05m from its axis, what will be the new revolution per minute of the disc? **(03 marks)**
- (b) Explain briefly why a:
(i) high diver can turn more somersaults before striking the water? **(1.5 marks)**
(ii) dancer on skates can spin faster by folding her arms? **(1.5 marks)**
- (c) A heavy flywheel of moment of inertia 0.4kgm^2 is mounted on a horizontal axle of radius 0.01m . If a force of 60N is applied tangentially to the axle:
(i) Calculate the angular velocity of the flywheel after 5 seconds from rest. **(02 marks)**
(ii) List down two assumptions taken to arrive at your answer in 6 (c) (i). **(01 mark)**

SECTION B (30 Marks)

Answer **three (3)** questions from this section.

7. (a) (i) Give two ways in which the internal energy of the system can be changed. **(1 mark)**
(ii) List down two simple applications of the First law of thermodynamics in our daily life. **(1 mark)**
- (b) One mole of a gas expands from volume, V_1 to a volume V_2 . If the gas obeys the Van-der-Waal's equation; $(p + \frac{a}{v^2}) (v - b) = RT$, derive the formula for work done in this process. **(3 marks)**
- (c) A heat engine works at two temperatures of 27°C and 227°C . Calculate the:
(i) Efficiency of the engine. **(3 marks)**
(ii) Temperature which will increase the efficiency by 10% if the room temperature is kept at 27°C . **(2 marks)**
8. (a) (i) Define thermal convection. **(01 mark)**
(ii) Prove that at a very small temperature difference, $\Delta T = T_b - T_s$ Newton's law of cooling obeys Stefan's law, whereby T_b is the temperature of the body and T_s is the temperature of the surrounding. **(04 marks)**
- (b) (i) What is meant by temperature of inversion?. **(01 mark)**
(ii) A thermometer was wrongly calibrated as it reads the melting point of ice as -10°C and reading a temperature of 60°C in place of 50°C . What would be the temperature of boiling point of water on this scale? **(04 marks)**
9. (a) What is meant by the following terms:
(i) Alternating current (a.c.). **(01 mark)**
(ii) Effective value of A.C. **(01 mark)**
- (b) A 60volt, 10watt lamp is to be run on 100volt, 60Hz A.C. mains.
(i) Calculate the inductance of a choke coil required. **(02 marks)**
(ii) If a resistor is used in (b) (i) above instead of choke, what will be the value of its resistance? **(01 mark)**
- (c) An LCR circuit with $R = 70\Omega$ in series with a parallel combination of $L = 1.5H$ and $C = 30\mu F$ is driven by a 230V supply with angular frequency of 300rad/s .
(i) Find the power in put to the circuit. **(3.5 marks)**
(ii) At the frequency $\omega_0 = \frac{1}{\sqrt{LC}}$, how does the circuit respond? **(1.5 marks)**
10. (a) Define the following terms:
(i) Current density **(01 mark)**
(ii) Conductivity. **(01 mark)**

- (b) (i) Under what condition is Ohm's law true? **(01 mark)**
(ii) Why does the voltage across the terminals of a cell or battery fall when it is delivering a current? **(02 marks)**
- (c) (i) Define temperature coefficient of resistance. **(01 mark)**
(ii) A heating coil of Nichrome wire with cross sectional area of 0.1mm^2 operate on a 12V supply, and has a power of 36W when immersed in water at 373K . Calculate the length of the wire. **(04 marks)**

SECTION C (30 Marks)

Answer **three (3)** questions from this section.

11. (a) What is meant by the following electronic circuits:
(i) Logic gates **(01 mark)**
(ii) Integrated circuits. **(01 mark)**
- (b) Draw a truth table for the circuit in Figure 1 including the states at C, D, E, F and G. **(3.5 marks)**

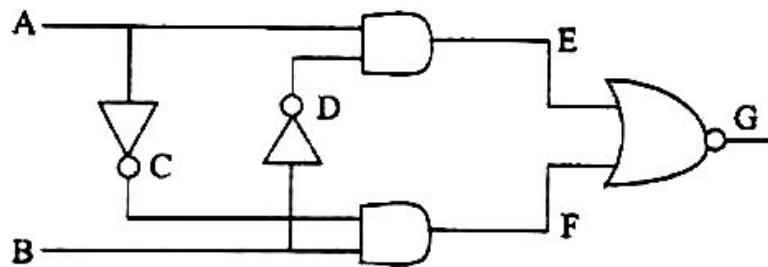

Figure 1

- (c) Study the circuit in Figure 2 then answer the questions that follow:

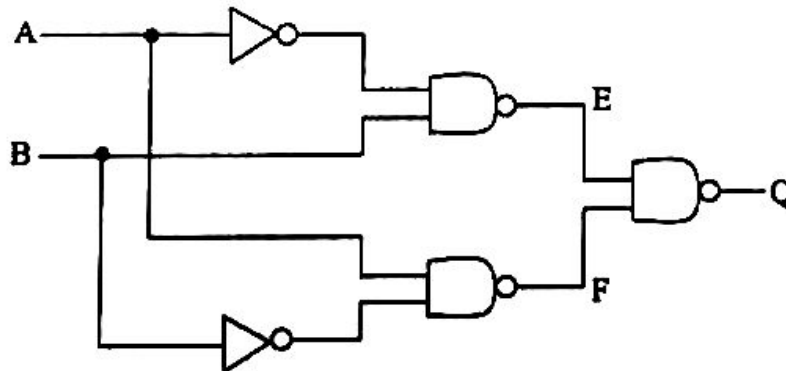
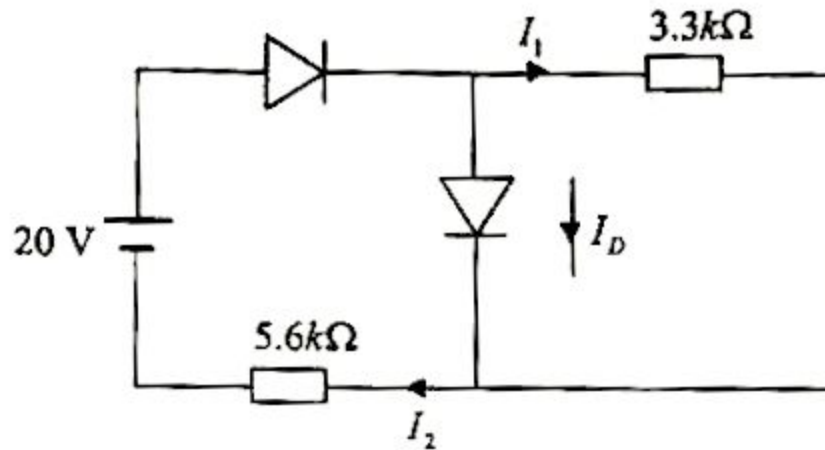

Figure 2

- (i) What type of a single gate would provide exactly the same function as the circuit in Figure 2. **(3.5 marks)**
(ii) Draw the diagram of a symbol representing a single gate in 11 (c) (i). **(01 marks)**

12. (a) (i) What is a light emitting diode (LED). **(01 mark)**
(ii) Give three advantages of LED's lamp in radio and other electronic systems over filament lamps. **(1.5 marks)**
- (b) (i) What is the basic difference between good conductors and semiconductors. **(01 mark)**
(ii) Two silicon diode each of forward bias voltage of 0.7V are connected in a circuit as shown below: **(3.5 marks)**



Calculate the value of I_1 and I_2 .

- (c) (i) Mention two types of transistors. **(01 mark)**
(ii) Which among the transistors mentioned in (c) (i) above responds quickly to electrical signal? Give reason for your answer. **(02 marks)**
13. (a) Give the meaning of the following terms:
(i) Bandwidth **(01 mark)**
(ii) Amplitude modulated carrier wave. **(01 mark)**
- (b) (i) What is the purpose of amplifiers in a phone link? **(01 mark)**
(ii) Sketch the frequency spectrum for 1500m radio waves modulated by a 4kHz audio signal. **(02 marks)**
- (c) (i) List down two advantages of digital signals over analogue signals. **(02 marks)**
(ii) A carrier of frequency 800kHz is amplitude modulated by frequencies ranging from 1kHz to 10kHz. What frequency range does each sideband cover? **(03 marks)**
14. (a) Describe the sources and effects of the following pollutants on the environment:
(i) Air pollution. **(03 marks)**
(ii) Radiation pollution. **(03 marks)**
- (b) Briefly explain the influence of the following climatic conditions for plant growth and development:
(i) Rainfall and water. **(02 marks)**
(ii) Wind. **(02 marks)**